

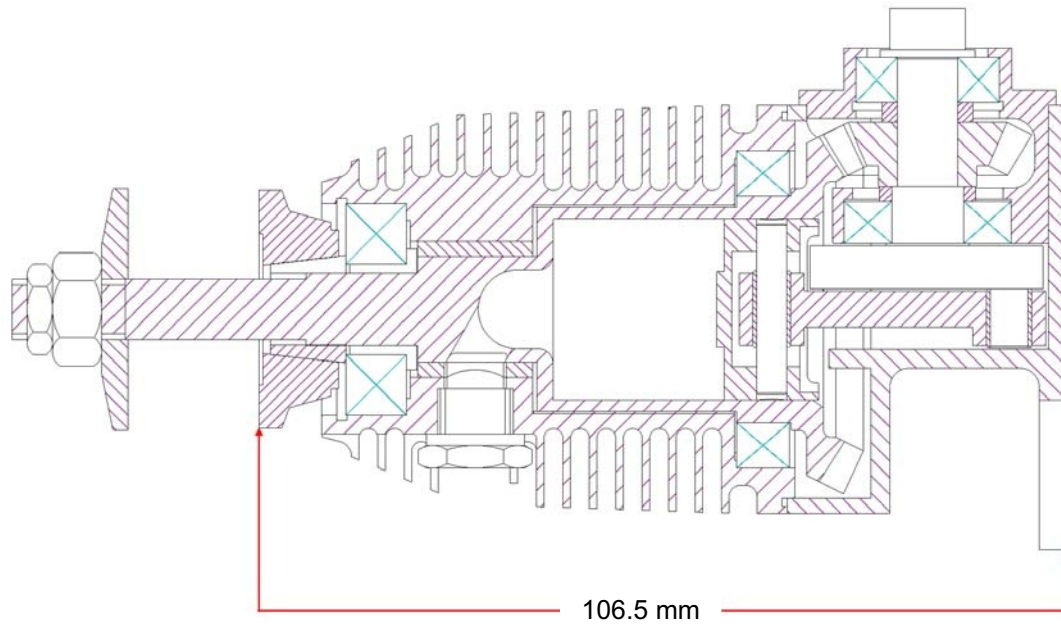

## RCV60SP - Engine Dimensions

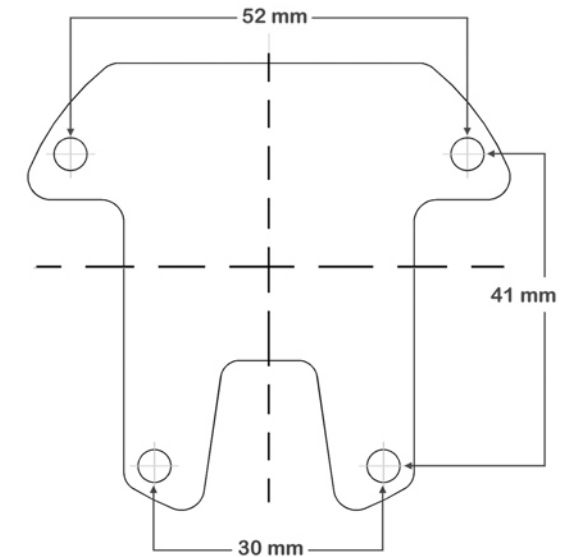

## Centre Line for Mounting



To assist you with mounting, please use the template above.  
Cut this out and line up with your engine.  
Then simply mark through the centre directly onto your engine backplate.

## RCV60-SP Specifications

	Displacement	Weight inc. silencer	Prop Shaft Dia	Exhaust Thread	Practical rpm @ prop	Cowling clearance	2-blade Prop sizes	3-blade Prop sizes	4-blade Prop size	Glow Plug	Approx. fuel consumption
Imperial	0.6 cu in	21.93 oz	5/16" UNF	M10 x 0.75	1400 - 6000 rpm	R36	14x14, 15x14, 16x12, 16x14	13.4x13.5 15x13W 15x13.5	13x13 14.5x11	OS 'F'	> 0.4 fl oz/min
Metric	10 cc	605 g									

Weston UK

84-88 London Road, Sittingbourne, Kent, England, ME9 9QH

Tel:+44 1795 521030 Tel/Fax +44 1795 522020